

PROFESSIONAL IONISATION / PHOTOELECTRIC SMOKE ALARM INSTALLATION INSTRUCTIONS

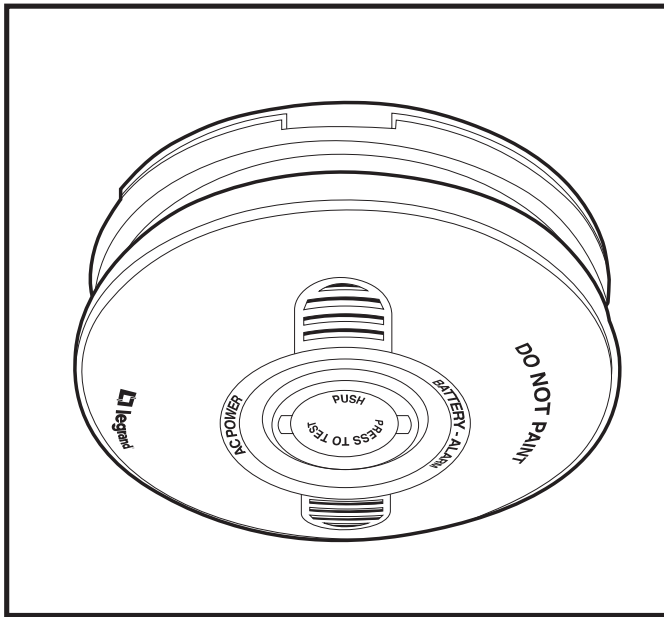

Specifications:

Cat No.	643084 (Ionisation) 643085 (Photoelectric)
Supply Voltage	230-240V a.c.
Frequency	50Hz
Backup Battery	9V battery included (recommended replacement: Energizer 522, Duracell MN 1604 or MX 1604)
Temperature Range	+5°C to ~ +50°C
Humidity Range	10-95% at 20°C
Siren Sound Level	> 85 dB at 3 metres



WARNING: THIS DEVICE CONTAINS A SMALL AMOUNT OF RADIOACTIVE MATERIAL.

Applicable to 643084 Ionisation alarm only.

IMPORTANT: READ ALL INSTRUCTIONS BEFORE INSTALLATION.
NO USER SERVICEABLE PARTS INSIDE THIS SMOKE ALARM.
Do not attempt to repair the smoke alarm yourself.

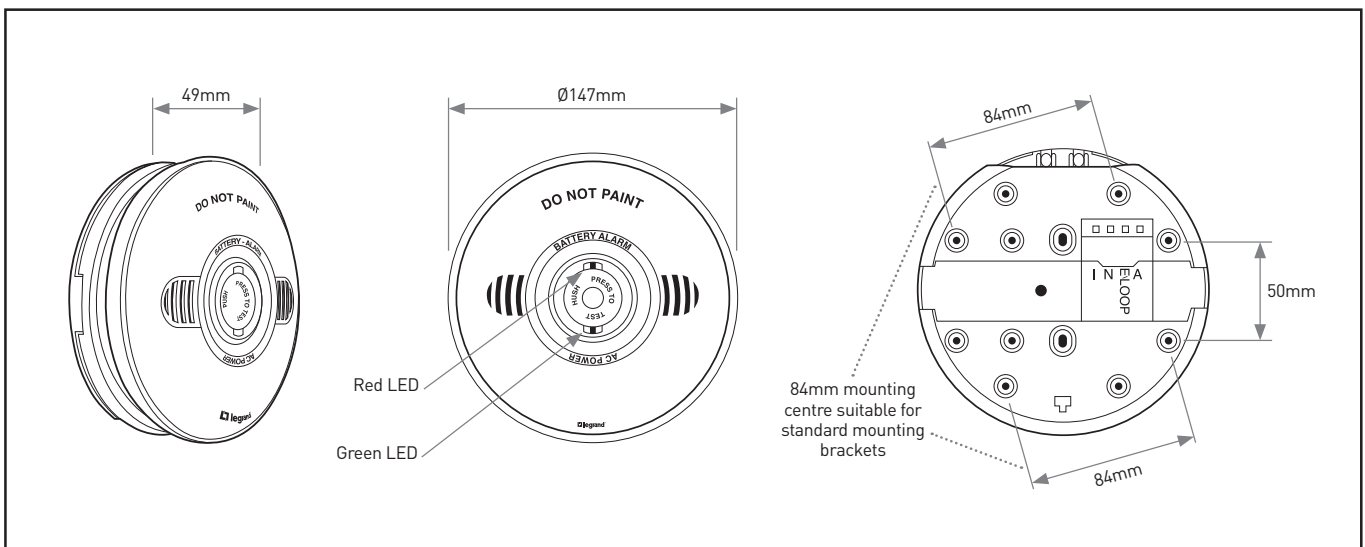

Installation:

WARNING: In the interests of safety, a licensed electrician, in accordance with the relevant requirements of AS/NZS 3000, must install this smoke alarm and all wiring.

This alarm must be wired to a continuous 230-240V a.c. 50Hz circuit. Ensure any switching device cannot inadvertently override the unit.

NOTE: See overleaf for recommended locations of alarms

INSTALLER PLEASE NOTE:

- Before you connect the mains power, check wiring polarity.
- If the alarm 'chirps' press the Test button to check the battery condition. Replace battery if necessary.
- If 'chirps' persist return smoke alarm to your supplier.

WIRING INSTRUCTIONS:

- This smoke alarm can be interconnected with other 643084 or 643085 smoke alarms. Interconnection with other brands or models may cause damage or result in a shock or fire risk.
- Up to a limit of 20 smoke alarms may be interconnected.
- **Not interconnectable with HPM 645/3 ionisation smoke alarm**

- There are four terminals in the supply terminal block, marked A, I, N and E/LOOP. It is important that the alarm be wired correctly to ensure correct operation. Incorrect wiring to the smoke alarm will damage the unit and invalidate the warranty. See wiring diagrams.
- **A maximum length of 300 metres of wire can be used in interconnecting smoke alarms. Spacing between interconnected smoke alarms must not exceed 30m per alarm.**
- Interconnected smoke alarms must be connected to the same final sub-circuit.
- Do not use any wire that could later be confused with the normal house wires for the interconnect wire. For example, green/yellow earth wire.
- Do not connect AC power wires to I interconnect terminal. This may damage smoke alarms.
- Do not connect the I interconnect wire to any device, except the I interconnect terminal of another 643084 or 643085 smoke alarm or interface 643086. Otherwise, smoke alarms will be damaged.
- Smoke alarms should be interconnected only within the confines of a single-family living unit. If smoke alarms are interconnected between different units, there may be excessive nuisance alarms. Residents may not be aware that smoke alarms are being tested or that it is a nuisance alarm caused by cooking, etc.

PROFESSIONAL IONISATION / PHOTOELECTRIC SMOKE ALARM

INSTALLATION INSTRUCTIONS

Installation:

■ Terminals at back of mounting base are marked as follows:

A - Active **I** - Interconnect **N** - Neutral **E/Loop** - Earth or Loop

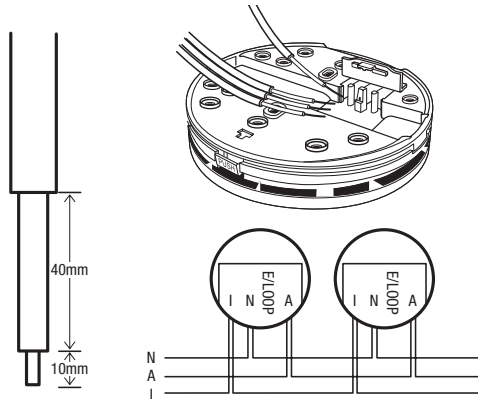

EXAMPLE OF MULTIPLE ALARM WIRING:

When interconnected, all smoke alarms will sound upon activation. However, only the originating smoke alarm will have flashing Red LED.

WARNING: Connecting the Interconnect terminal to any supply conductor will result in damage to the alarm, failure to operate or shock hazard and will void the warranty of the alarm.

WARNING: Under no circumstances must an insulation resistance test be carried out on a circuit to which a smoke alarm is connected.

The test could cause irreparable damage to the internal circuitry of the smoke alarm and make it inoperative.

The warranty would be void under such circumstances.

Mounting Instructions:

1. Write down the date of installation on label provided.
2. Strip the Active/Neutral and Interconnect (if used) wires back to the strip length shown above.
3. Connect the wires to the correct terminals on the base as indicated and ensure the screws are fully tightened.
4. Clip the flap closed to prevent accidental contact with the live terminals.
5. Screw the mounting base to the ceiling or wall using the plugs and screws provided or No.6/No.8 superscrews.
6. Install the 9V battery. The smoke alarm will not latch to the base unless battery is installed.
7. Turn on the mains power and check the green and red LED function. Green LED should glow to show main power present. Red LED will pulse every 60 seconds to indicate correct operation and the 9V battery is OK.
8. Press the Test/Hush button for 5 seconds to check the alarm works.
9. When installing onto a wall the mounting hinge must be on left hand side.

Operation, Testing and Maintenance:

OPERATION

The smoke alarm is operational once all wires are properly connected, the smoke alarm is correctly installed on the mounting base, battery inserted and the alarm has been tested. There are two LED indicators. Each of them has a unique function:

Red LED

- **Stand-by condition:** will flash once approximately every 60 seconds to indicate unit is functioning properly.
- **Alarm condition:** will flash quickly when unit goes into alarm. The flashing red LED and pulsating alarm will continue until the air is cleared. For interconnected units, the originating smoke alarm red LED will be flashing. All other units will sound but not flash.

Green LED

- **AC Mains-ON Indicator:** indicates that the unit is operating with AC power. If this LED goes out, it indicates that the AC power is off.

False Alarm Hush Control Feature:

- This smoke alarm has the capability of being temporarily desensitised for approximately 10 minutes.
- If the smoke alarm is sounding it can be desensitised by pressing the "HUSH/TEST" button on the smoke alarm cover.
- After pressing the "HUSH/TEST" button, the alarm will silence immediately and red LED will flash every 15 seconds for approximately 10 minutes to indicate the alarm is in the temporary desensitised condition.
- The smoke alarm will automatically reactivate after approximately 10 minutes and sound the alarm if particles of combustion are still present.
- The "HUSH" feature may be used repeatedly until the air has cleared.

TESTING

NOTE: Before testing, make sure that the smoke alarm is connected to AC power supply (make sure the green LED is ON) and there is a 9V battery properly installed.

- Test alarm by pushing and holding the test "HUSH/TEST" button for 5 seconds. This should sound the alarm if all electronic circuitry and horn are working.
- If no alarm sounds, check battery wiring, fuses or circuit breaker and make certain that alarm is connected to a continuous final sub-circuit.
- With interconnected units, holding test button down on one unit will cause all connected units to sound.
- Continuous chirping or erratic noise or low sound from an alarm may indicate a defective alarm.

Smoke alarm should be tested on a monthly basis. To accurately test the integrity of the sensing chamber use a smoke detector (aerosol) tester.

NOTE: After the above alarm test with the "HUSH/TEST" button, the alarm will be desensitised for about 10 minutes. **ONLY DO THE SMOKE AEROSOL TEST AFTER THIS DESENSITISED PERIOD.**

WARNING: Do not apply excessive force on the "HUSH/TEST" button this may damage the smoke alarm and may void the warranty.

WARNING: Never use an open flame of any kind to test your alarm. You may damage the alarm or set fire to your home. The built-in test switch enables testing of all electronic components and the horn.

MAINTENANCE

The smoke alarm is virtually maintenance free. However, under dusty or greasy conditions, a vacuum cleaner may be used to clean the exterior of unit (including slots on cover). **DO NOT IMMERSE IN OR SPRAY WITH HOUSEHOLD CLEANERS.**

If the unit gives a chirping sound every 60sec the battery may need to be replaced.

Battery:

BATTERY INSTALLATION

- The smoke alarm uses one 9V battery to automatically provide back-up power to the alarm if AC power fails. The battery will operate the alarm for approximately one to three months with AC power off.
- **USE ONLY BATTERIES AS SPECIFIED IN THE PRODUCT LABEL. USE OF A DIFFERENT BATTERY MAY HAVE A DETRIMENTAL EFFECT ON OPERATION OR MAY CAUSE THE BATTERY TO EXPLODE.**
- **USE ONLY THE FOLLOWING 9-VOLT ALKALINE BATTERIES FOR REPLACEMENT: EVEREADY/ENERGIZER 522 DURACELL MN1604, MX1604**
- Battery can only be inserted in one direction. Ensure polarity is correct.

BATTERY REPLACEMENT

- To replace battery, unlatch unit from mounting base and remove the battery from compartment. Replace the old battery with a fresh one and close unit. Verify that the green LED is on.
- To ensure proper operation, the battery should be replaced once a year.
- Smoke alarm cannot be closed properly without battery in place.

Repairs and Services:

- If the smoke alarm is defective in any way, do not tamper with the unit. See warranty for instructions on in-warranty returns. **Note: NO USER REPLACEABLE PARTS INSIDE.**

643084 only:

- The smoke alarm uses a very small amount of radioactive element that is safely contained within the sealed source.

NOTE: When this product is no longer required dispose by returning to HPM Legrand office in your state capital or your state's Health Department. Alternative disposal is not permitted unless accepted under your state's Health and Safety Regulations.

- **Please note:** It is illegal to send radioactive material through Australia Post. Check for similar conditions with any forwarding agency before sending this article.

WARNING: DO NOT TAMPER WITH RADIOACTIVE SOURCE.

Recommended Locations of Alarms:

- Install at least one alarm for each separate sleeping area. Try to cover the exit path as the bedrooms are usually farthest from an exit. If there is more than one sleeping area, install additional alarms in each sleeping area in the immediate vicinity of bedrooms.
- Install at least one alarm to protect any stairway as stairways act like chimneys for smoke and heat.
- Install at least one alarm on every floor level.
- Install an alarm in every room where a smoker sleeps as additional protection.
- Install an alarm in every room where electrical appliances are operated (i.e. portable heaters or humidifiers) as additional protection.
- Install an alarm in every room where someone sleeps with the door closed as additional protection. The closed door may prevent the alarm from waking the sleeper.
- Smoke, heat and other combustion products rise to the ceiling and spread horizontally. Mounting the alarm on the ceiling in the centre of the room places it closest to all points in the room. Ceiling mounting is preferred in ordinary residential construction.
- For mobile home installation select location carefully to avoid thermal barrier that may form at the ceiling. For more details see Mobile Home Installation.
- When mounting an alarm on the ceiling install it at a minimum of 300mm from the side wall and 600mm from any corner (see diagram).
- When mounting an alarm on a wall, install it at a minimum of 300mm from the ceiling level but not more than 600mm from the ceiling level and any corner (see diagram) NOTE: The performance of smoke alarms mounted on a wall is unpredictable, and is not recommended when ceiling mounting can be implemented.
- When mounting an alarm at the apex of a sloping ceiling it should be located a minimum of 500mm from the apex but should not exceed 1500mm (see diagram).
- Locate smoke alarm at both ends of a bedroom hallway if the hallway is more than 9m long.

Installation of Smoke Alarms:

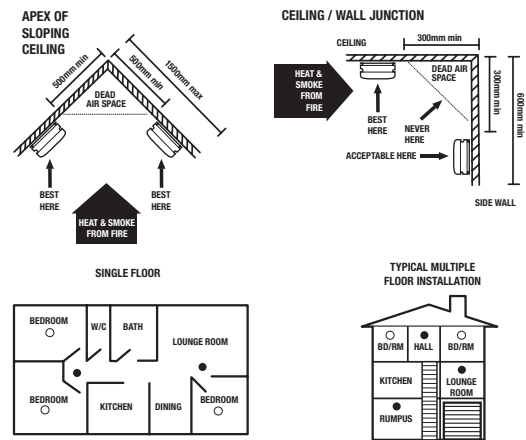

- Smoke alarms for minimum protection.
- Smoke alarms for additional protection.

IMPORTANT: INCORRECT ORIENTATION OF SMOKE ALARMS MAY DECREASE OPERATIONAL EFFECTIVENESS

Mobile Home Installation:

- Modern mobile homes have been designed and insulated to be energy efficient. Install smoke alarms as recommended (refer to RECOMMENDED LOCATIONS).
- In mobile homes that are not well insulated extreme heat or cold can be transferred from the outside through poorly insulated walls and roof. This may create a thermal barrier that can prevent smoke from reaching a smoke alarm mounted on the ceiling. In such units, install the smoke alarm on inside partition between 300mm and 600mm from the ceiling.
- If you are not sure about the insulation in your mobile home, or if you notice the walls and ceilings are either hot or cold, install alarm on an inside wall. For minimum protection, install one alarm close to the bedrooms.

For additional protection, see SINGLE FLOOR plan. We recommend that the smoke alarm be tested after each journey.

Avoid These Locations:

Do not place alarm in the following locations:

- The garage. Gas released when you start your automobile may cause false alarms.
- In front of forced air supply ducts used for heating and air-conditioning and other high airflow areas.
- In the peak of an "A" frame type of ceiling.
- In areas where temperatures may fall below +5°C or rise above +50°C.
- In dusty areas, dust particles may cause smoke alarm to false alarm or fail to alarm.
- We do not recommend installation in or directly adjacent to areas of high condensation such as bathrooms & laundries due to potential for false alarms.
- Kitchen/cooking areas.

Good Safety Habits:

The use of this product should not be seen as a substitute for basic safety precaution in the prevention of fire.

- Do not smoke in bed.
- Do not leave children at home alone.
- Do not clean with flammable liquids, such as petrol.
- Safely store flammable materials.
- Smoke alarms must be tested regularly to ensure that the batteries and alarm circuit are in good operating condition.

The Limitations of Smoke Alarms:

- Smoke alarms cannot provide an alarm if smoke does not reach the alarm. Therefore, smoke alarms may not sense fires starting in chimneys, walls, on roofs, on the other side of a closed door, or on a different floor.
- If the alarm is located outside the bedrooms, or on a different floor, it may not wake up sound sleepers. A smoke alarm in the bedroom, is therefore recommended as additional protection.
- Smoke alarms have been significant in saving lives in many parts of the world. However, U.S. Government research indicates that they may not give early enough warning in up to 35% of fires. Hence, the use of this product does not act as a substitute for basic prevention.
- Although smoke alarms can help save lives by providing early warnings of a fire, they are not a substitute for an insurance policy.
- This smoke alarm alone will not alert the hearing impaired. Use special purpose smoke alarm with lights or vibrating devices, for those hard of hearing.

False Alarms:

- In very humid areas or near a bathroom, moisture can cause false alarms in Ionisation smoke alarms.
- This smoke alarm is designed to minimise false alarms. Smoking will not normally set off the alarm unless smoke is blown directly into the alarm.
- Combustion particles from cooking may set off the alarm if the alarm is located close to the cooking surface.
- Because large quantities of combustion particles are generated from spills or grilling an alarm with a Hush Control device is preferable near a kitchen environment.
- If the alarm does sound, check for a fire before silencing the alarm. If a fire is discovered, escape quickly and call the Fire Brigade.

Develop and Practise a Plan of Escape:

- Make a floor plan indicating all doors and windows and at least two escape routes from each room. Second storey house windows may need a rope or chain ladder.
- Have a family meeting and discuss your escape plan, showing everyone what to do in case of fire.
- Determine a place outside your home where all of you can meet, if a fire occurs.
- Familiarise everyone with the sound of the smoke alarm and practice leaving your home when they hear it.
- Practice a fire drill at least every six months, including drills at night. Practice allows you to test your plan before an emergency. You may not be able to reach your children. It is important that they know what to do!

What to do when the Alarm Sounds:

- Leave immediately by your plan of escape. Every second counts, so don't waste time getting dressed or picking up valuables.
- In leaving, don't open any inside door without first feeling its surface. If hot, or if you see smoke seeping through cracks, don't open that door! Instead, use your alternative exit. If inside door is cool, place your shoulder against it, open it slightly and be ready to slam it shut if heat and smoke rush in.
- Stay close to the floor if air is smoky. Breathe shallowly through a wet cloth if possible.
- Once outside, go to your selected meeting place and make sure everyone is there.
- Call the Fire Brigade from your neighbour's home - not from yours!
- Don't return to your home until officials say that it is safe to do so. For additional information on fire safety, contact your local Fire Brigade.

Disclaimers:

1. This product must be installed by a licenced electrician.
2. For indoor use only
3. This product should not be installed in areas exposed to constant vibration, temperature fluctuations, or areas of high humidity.
4. This product contains no serviceable parts and no attempt should be made to repair this product. If the product is faulty it should be discarded.
5. Severe electromagnetic interference from other products may cause malfunction of this product.
6. Ionisation smoke alarms contain radioactive particles. Please refer to instructions for disposal requirements.
7. This product has a 10 year design life. At the end of this time it should be replaced. The date of Manufacture is coded on every alarm in the form B/N 15 March 2013.
8. This product has been designed to operate in ambient temperatures: 5°C to 50°C.
9. This product is not suitable for marine environments such as areas subject to salt spray and/or mist.
10. This product is not suitable for installation in hazardous and/or corrosive areas.
11. This product has been designed for domestic or similar uses and is not suitable for a commercial installation.
12. The material in this product may vary in colour from batch to batch. Colour matching from one batch to another cannot be guaranteed.
13. Electrical installations periodically receive transient over voltages. This product has been designed to minimise the effect of such voltages on connected equipment. It may not give full protection for extreme over voltage transients such as those resulting from a close lighting strike.
14. This product has been designed to operate on a nominal supply voltage of 230V - 240V a.c. ± 6%.
15. This product must be installed and used as per these instructions.
16. After installation this product must be tested as required by the appropriate government and/or statutory regulations.
17. This product utilises intellectual property in the form of registered designs, trademarks, and/or patents. Such intellectual property remains the property of HPM Legrand in all cases.
18. HPM Legrand reserves the right to modify the specification of this product at any time.

**This smoke alarm has a maximum 10 year life span. THIS SMOKE ALARM HAS BEEN TESTED AND PASSED TO AS3786-1993
DEAR ELECTRICIAN: PLEASE LEAVE THIS MANUAL FOR THE OWNER. THANK YOU FOR CHOOSING THIS SMOKE ALARM.**

Warranty

HPM Legrand will honour all statutory guarantees that you as a consumer are entitled to rely upon under the Australian and New Zealand Consumer Laws against a manufacturer including a guarantee that any products HPM Legrand has manufactured or imported are of acceptable quality.

To make a claim under any statutory guarantee (or other warranty) you should first contact the supplier, contractor or retailer from whom you purchased the products.

Customer Service

For all Customer Service and Technical Support enquires please call Monday to Friday during business hours.

HPM Legrand Australia
1300 369 777
www.legrand.com.au

HPM Legrand New Zealand
0800 476 009
www.legrand.co.nz

ABN: 31 000 102 661